

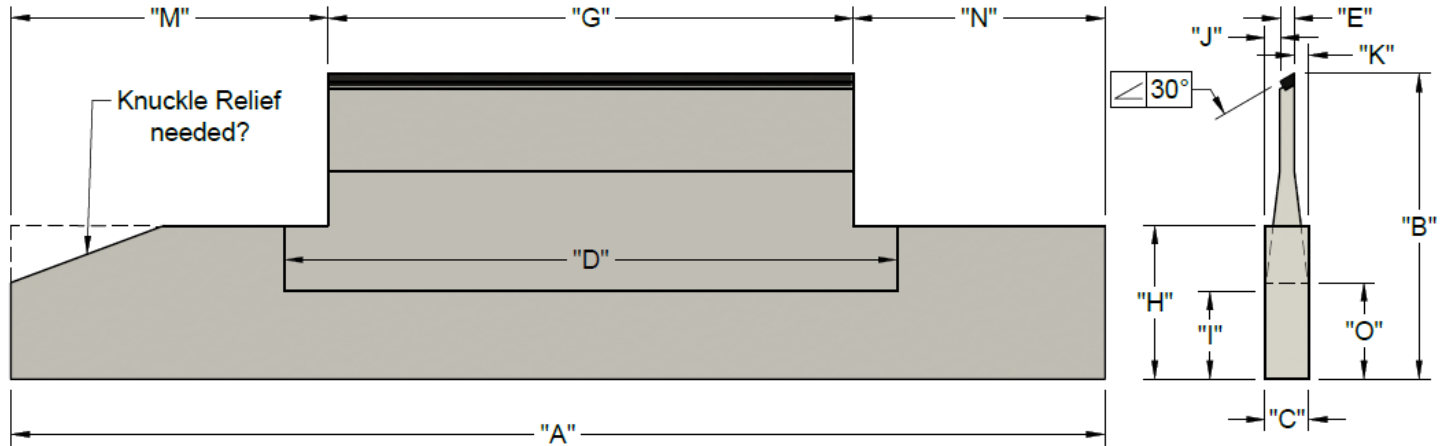

INFEED BLADE with Optional Dimensions

CUSTOM ORDER FORM

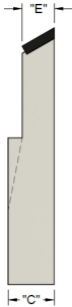
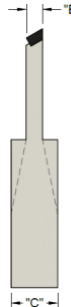

BLADE SHAPE / STYLE (check one)

<input type="checkbox"/> SHAPE 1 / STYLE 50 	<input type="checkbox"/> SHAPE 2 / STYLE 60 	<input type="checkbox"/> SHAPE 3 / STYLE 70 
---	---	---

WORKREST BLADE DIMENSIONS (SEE ABOVE)	
"A" – Length	
"B" – Height	
"C" – Body Width	
"D" – Pocket Length	
"E" – Tip Width	
"G" – Grind Length	
"H" – Shoulder Height	
"I" – Pocket Breakout (Reg Side)	
Rest Top Angle (if not 30°)	
OPTIONAL BLADE DIMENSIONS (SEE ABOVE)	

"J" – (if Shape 3 & "E" not central)	
"K" – (if Shape 3 & "E" not central)	
"M" – (if "G" is not central)	
"N" – (if "G" is not central)	
"O" – Pocket Breakout (Grind Side)	
Knuckle Relief needed? (as shown above)	<input type="checkbox"/> Yes

ADDITIONAL REQUESTS
(e.g. radius pocket, 6% carbide grade, etc.)